

Assembly Instructions

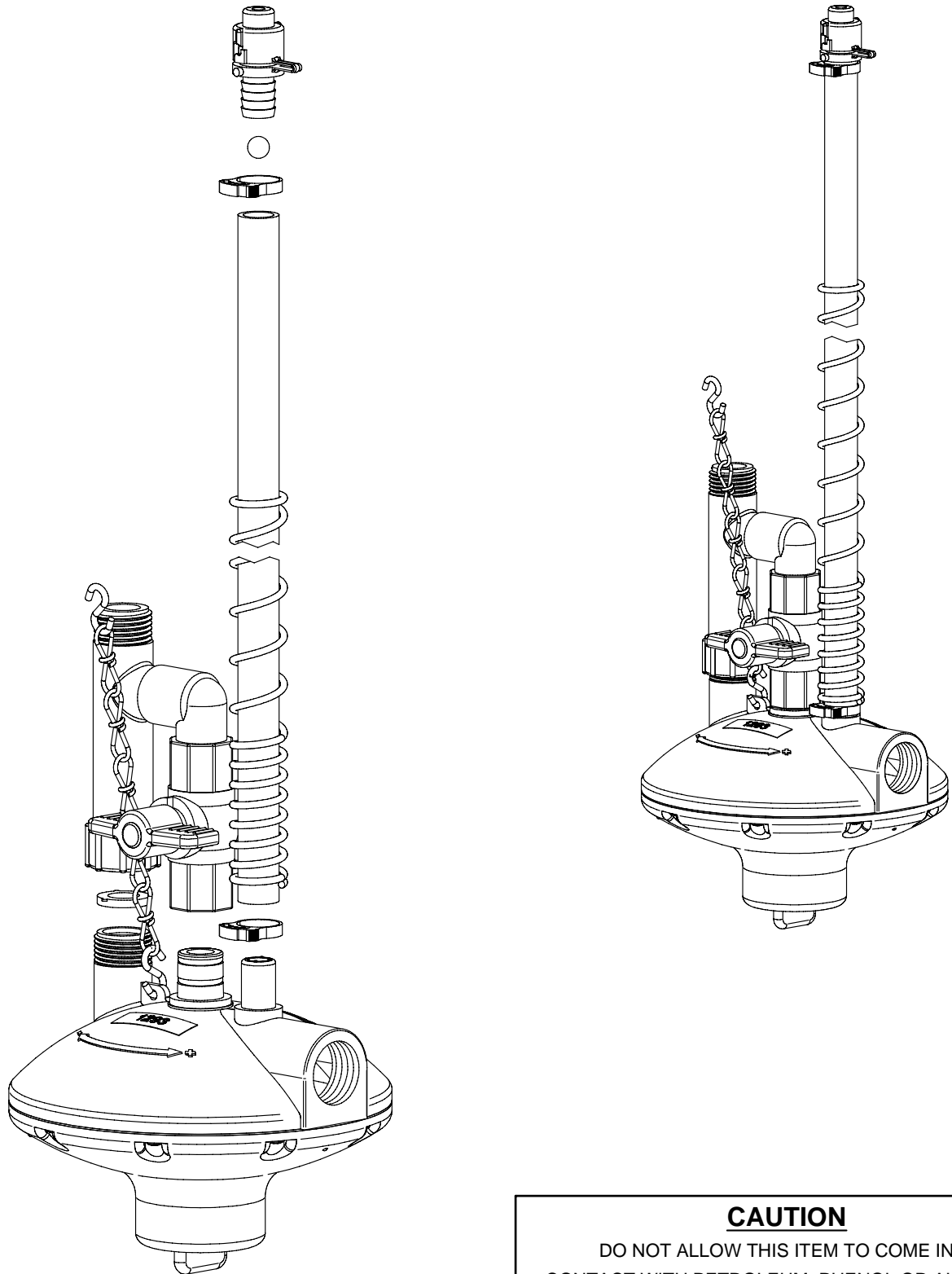

CAUTION

DO NOT ALLOW THIS ITEM TO COME INTO CONTACT WITH PETROLEUM, PHENOL OR ALDEHYDE BASED PRODUCTS OR ANY OTHER CORROSIVE PRODUCT IN GENERAL

COMPONENTS

PART NR.	QTY	DESCRIPTION
122-24	1	RISER TUBE: 24" / 60 CM
147	1	BALL: RISER TUBE
511	2	CLAMP: SNAP 0.746" - 0.848" DIA.
766	2	S-HOOK: 1"
767	1	CHAIN: DOUBLE LOOP #3 X 36" / 92 CM
1374	1	REGULATOR PART: FLUSH UNIT MHT INLET WHITE
2005	1	RISER TUBE CAP
83	9	FASTENER: SCREW PAN HD PHILLIPS #7 - 18 X 1/2" LG - PLASTITE THREAD
84	2	FASTENER: SCREW PAN HD PHILLIPS #8-15 X 5/8" LG
87	2	REGULATOR PART: RETAINER BLOCK - STANDARD
171	1	REGULATOR PART: ADJUSTMENT KNOB ASSEMBLY - STANDARD
187	1	REGULATOR PART: ADJUSTMENT HOUSING - STANDARD & INLINE
89	1	FASTENER: NUT HEX 5/16"-18 X 1/2" WD X 17/64" H
91	1	REGULATOR PART: SWIVEL COUPLING - STANDARD
92	1	REGULATOR PART: SHOULDER BOLT - STANDARD
97	1	REGULATOR PART: DIAPHRAGM BACKING PLATE - STANDARD
157	1	WASHER: METAL - 5/16" ID X 3/4" OD X 0.044" TH
181	1	REGULATOR PART: DIAPHRAGM 0 - 2.1 PSI
417	1	O-RING: 6.40MM ID X 10.21MM OD X 1.90MM CS
506	1	REGULATOR PART: SPRING 0.05 - 1 PSI
88-V	1	REGULATOR PART: OPENING ARM SEAT
93	1	REGULATOR PART: OPENING ARM - STANDARD W/O SEAT
1358	1	REGULATOR PART: INLET/OUTLET HOUSING - CAGE 1" FNPT
1895	1	SPRING: RISER TUBE

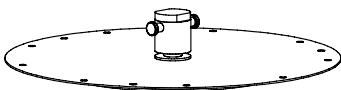
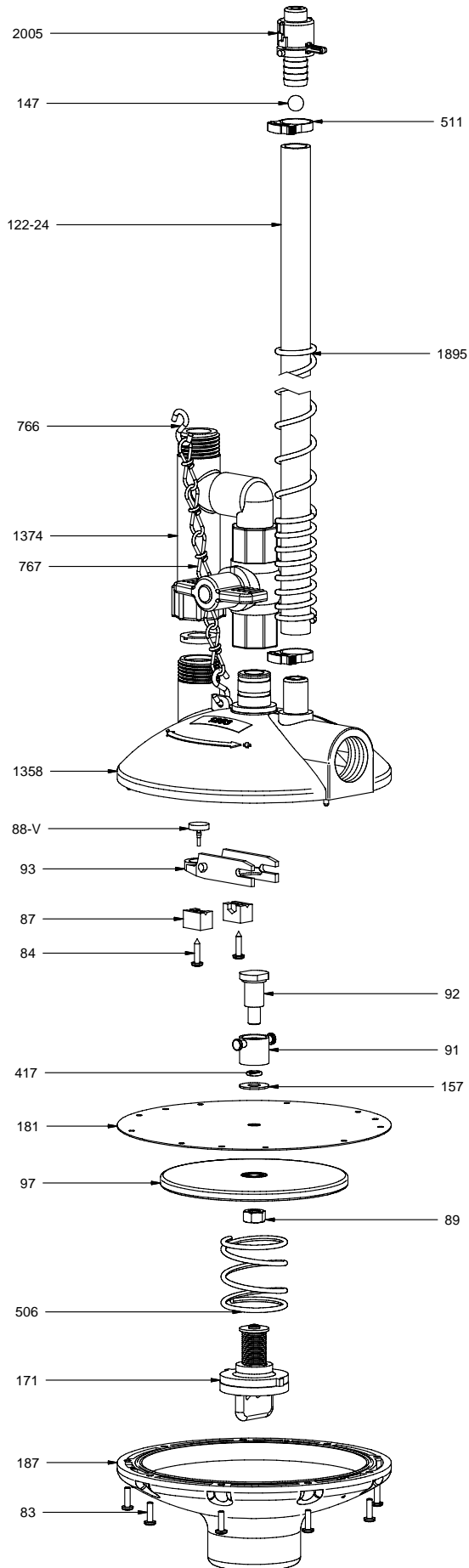

301 ASSEMBLY

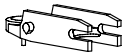

888 ASSEMBLY



P.O. Box 1169
 101 Industrial Parkway
 Middlebury, Indiana
 46540-1169, USA
 Tel: + 1 574.825.5849
 Fax: + 1 574.825.7674
 Web: www.ziggity.com