

Assembly Instructions

PART NR.	QTY	DESCRIPTION
122-24	1	RISER TUBE: 24" / 60 CM
147	1	BALL: RISER TUBE
260	2	PIPE CONNECTOR: ACE
511	2	CLAMP: SNAP 0.746" - 0.848" DIA.
1895	1	SPRING: RISER TUBE
2005	1	RISER TUBE CAP
2089	1	FASTENER: BOLT HEX HD M6 X 1 X 16 LG
2605	1	FASTENER: NUT HEX M6-1
2607	2	BRACKET: SUPPORT PIPE TO ASSEMBLY - ACE
2608	1	AIR RELEASE UNIT: FLOOR ACE
2652	1	FASTENER: LOCK WASHER - M6

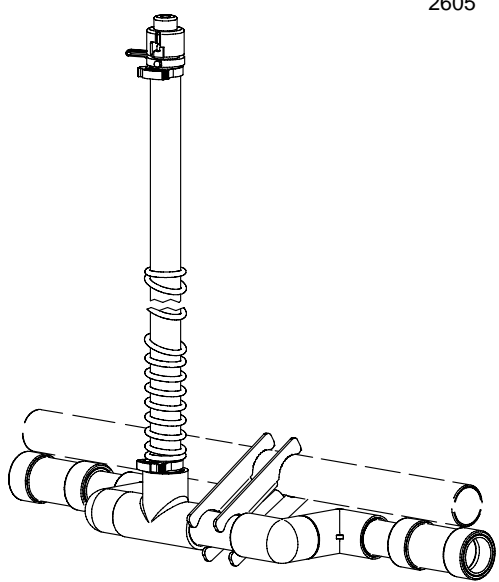

ASSEMBLED VIEW

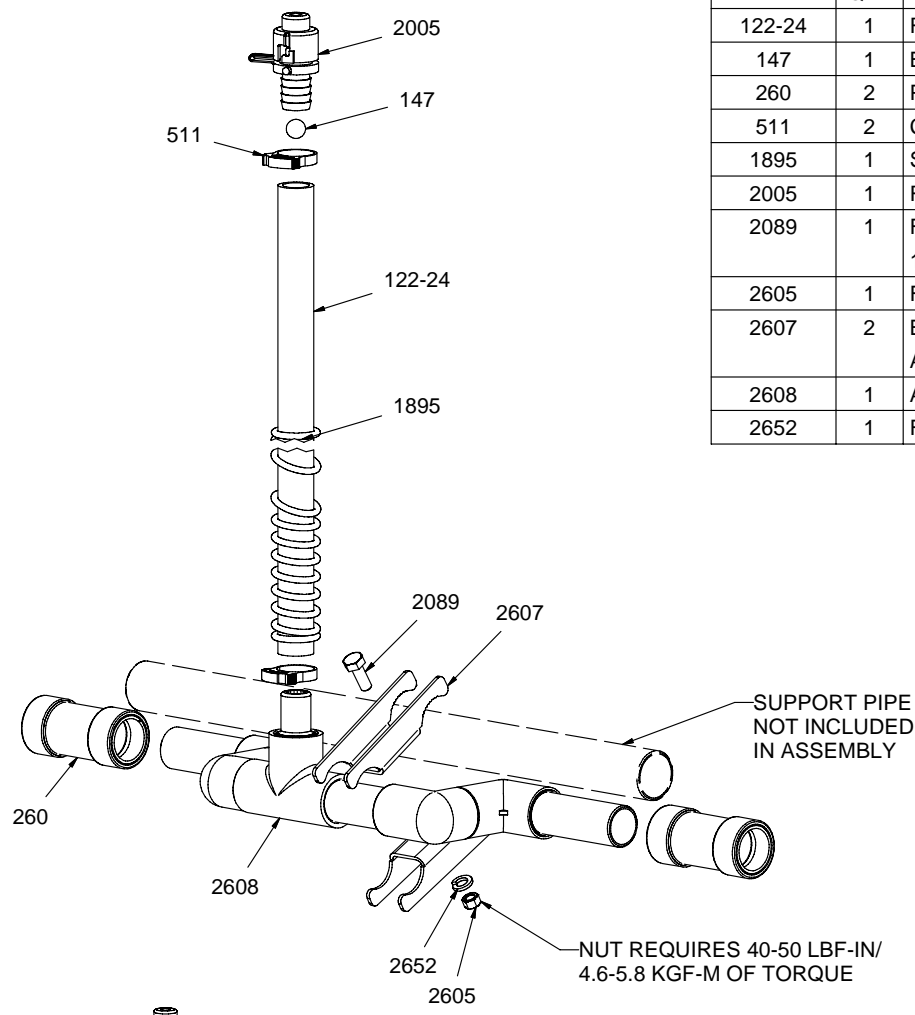
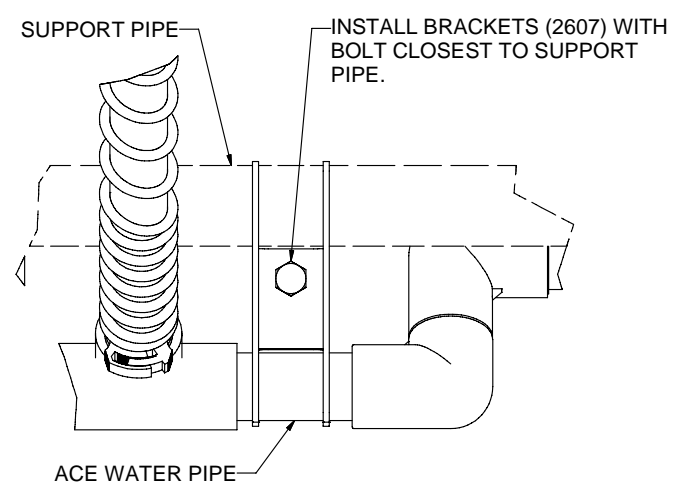

CAUTION

**AVOID ALL CONTACT WITH
PETROLEUM, ALDEHYDE & PHENOL
BASED PRODUCTS**

NEW INSTALLATION

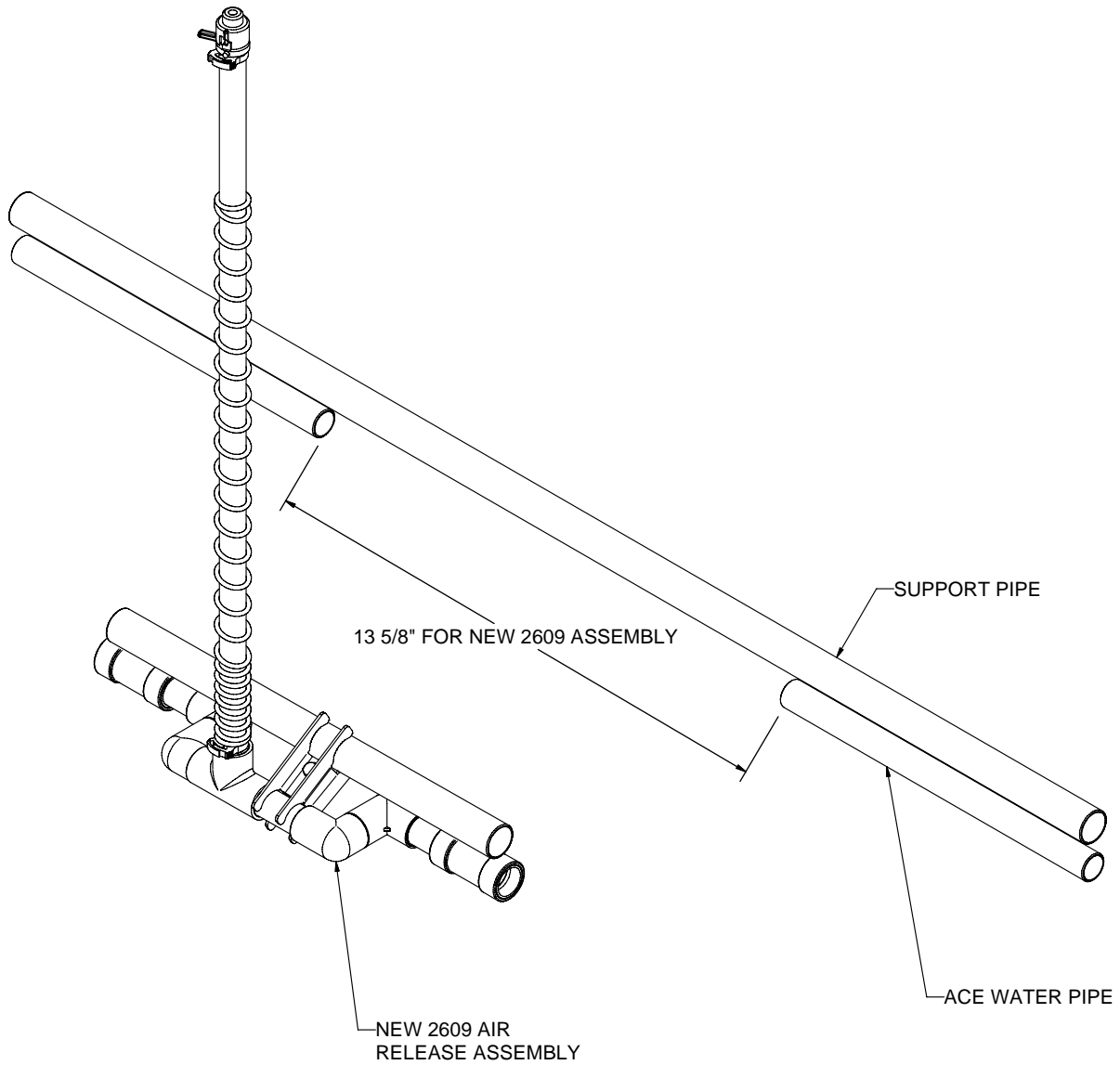

P.O. Box 1169
101 Industrial Parkway
Middlebury, Indiana
46540-1169, USA
Tel: + 1 574.825.5849
Fax: + 1 574.825.7674
Web: www.ziggity.com