

Assembly Instructions

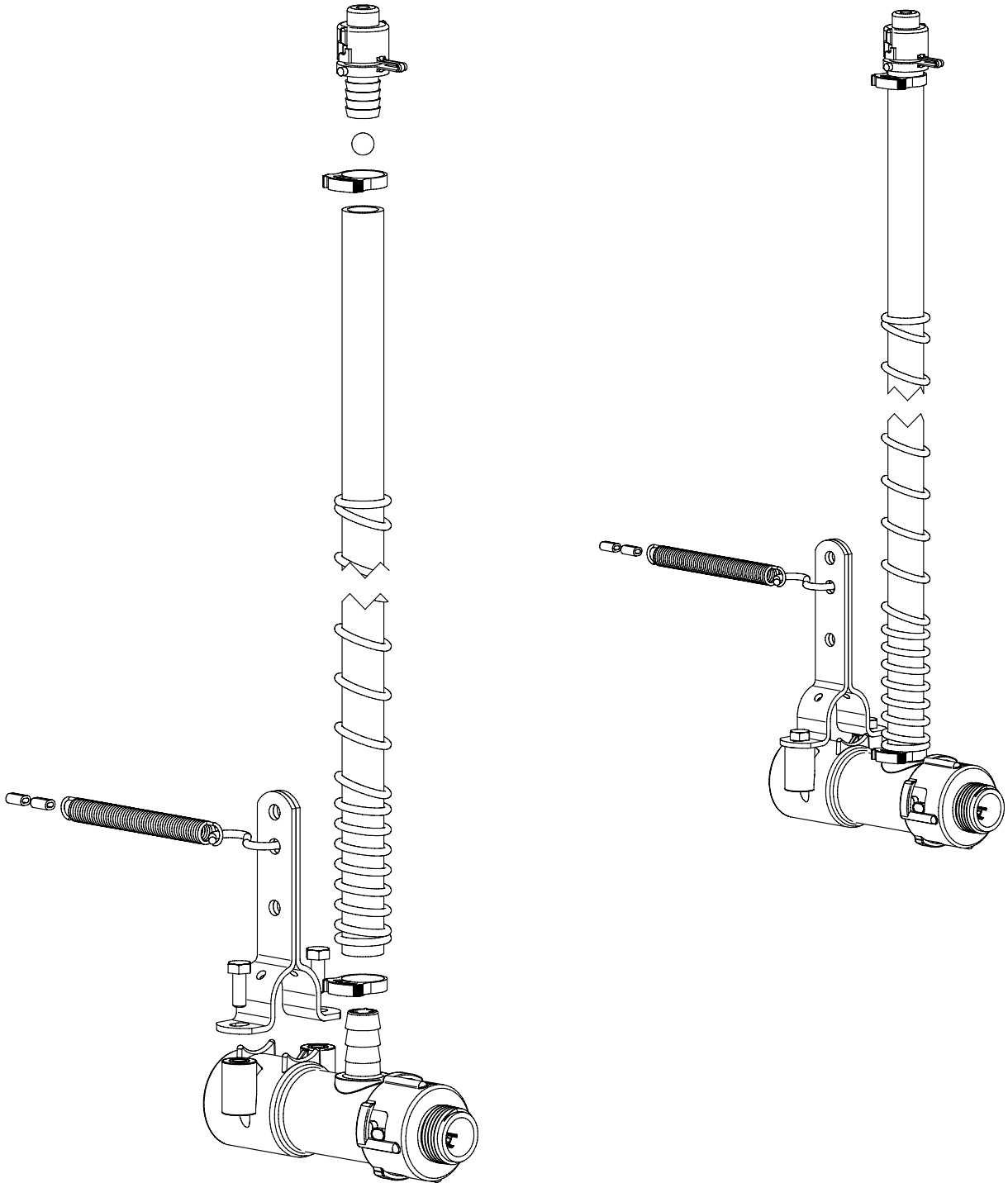

**CAUTION**

DO NOT ALLOW THIS ITEM TO COME INTO CONTACT WITH PETROLEUM, PHENOL OR ALDEHYDE BASED PRODUCTS OR ANY OTHER CORROSIVE PRODUCT IN GENERAL

# COMPONENTS

PART NR.	QTY	DESCRIPTION
122-24	1	RISER TUBE: 24" / 60 CM
147	1	BALL: RISER TUBE
1895	1	SPRING: RISER TUBE
2005	1	RISER TUBE CAP
206	1	SPRING: ANTI-ROOST
207	2	CLIP: ANTI-ROOST CABLE
2089	2	FASTENER: BOLT HEX HD M6 X 1 X 16 LG
1171	1	END ASSEMBLY PART: BALL
2617	1	FLOOR END ASSEMBLY PART: BODY
2618	1	FLOOR END ASSEMBLY PART: O-RING RETAINER
2620	1	FLOOR END ASSEMBLY PART: END CAP - MNPT
2621	1	O-RING: 209 - 0.671" ID X 15/16" OD X 0.139" CS
2622	1	FLOOR END ASSEMBLY PART: SPRING
2623	1	FLOOR END ASSEMBLY PART: END CAP RUBBER WASHER
2765	1	S-HOOK: ANTI-ROOST CABLE ANCHOR
511	2	CLAMP: SNAP 0.746" - 0.848" DIA.
898	1	CLAMP: SUPPORT PIPE TO FLOOR REGULATOR

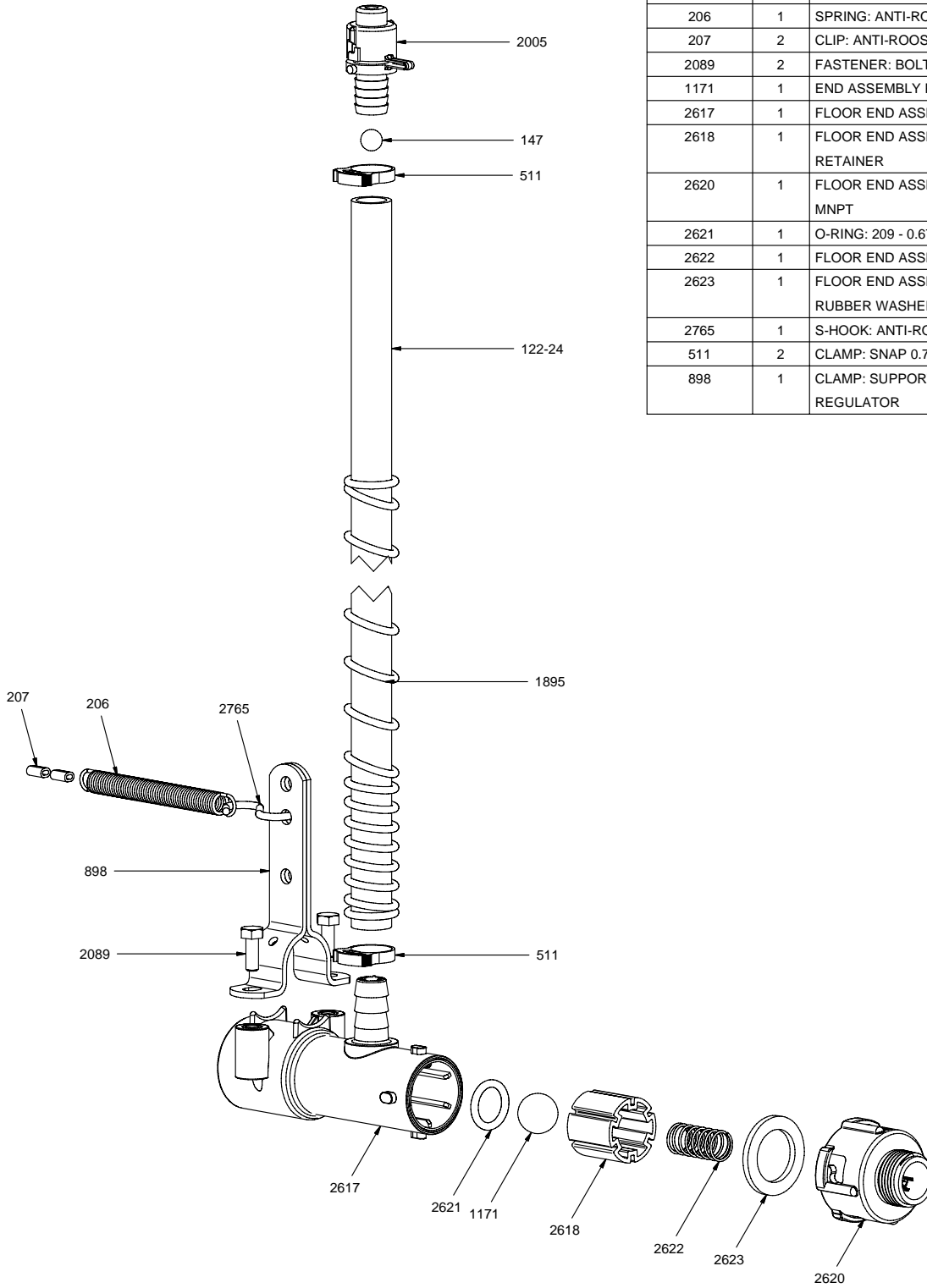



P.O. Box 1169  
 101 Industrial Parkway  
 Middlebury, Indiana  
 46540-1169, USA  
 Tel: + 1 574.825.5849  
 Fax: + 1 574.825.7674  
 Web: www.ziggity.com